

LIFESAVER SMOKE ALARM ISOLATION RELAY



- Suitable for connection to auxiliary devices, security alarm panels and fire indication panels.
- Operates in absence of mains voltage and only when smoke alarm is in alarm state.
- Relay switched from signal voltage (9V output) from smoke alarm.
- 240V AC / 30V DC 10Amp contact rating
- Normally Open and Normally Close contact options
- 24V DC input to trigger 4th terminal smoke alarms as part of an early warning system.

SPECIFICATIONS:

Operating Coil Voltage	6V – 10V DC
Secondary Contacts	Normally Open Normally Closed (change-over contacts)
Secondary Contact Rating	240V AC 50Hz @ 10Amps 30V DC @ 10Amps
Contact Switching Time Delay	8 seconds once activated
Maximum No. of interconnected smoke alarms to a single RK10A/9 unit	24
Operating Temperature	0° – 50°C
Dimensions	89mm Deep x 68mm Wide x 45mm High

Compatible with PSA's complete range of smoke alarms, heat alarms and strobe lights.

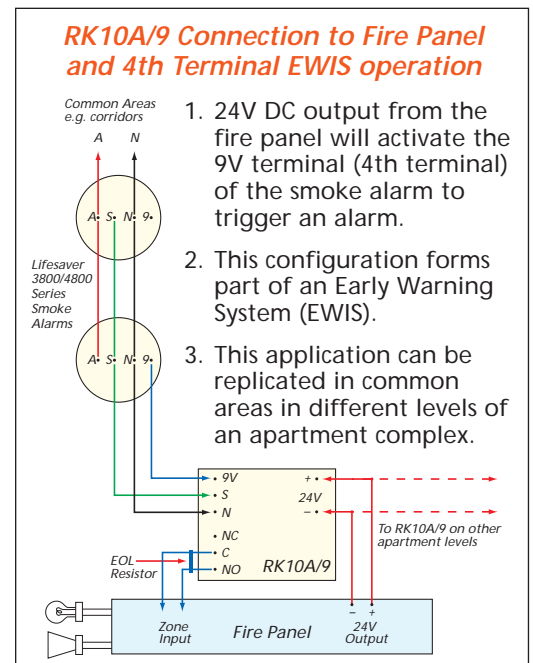
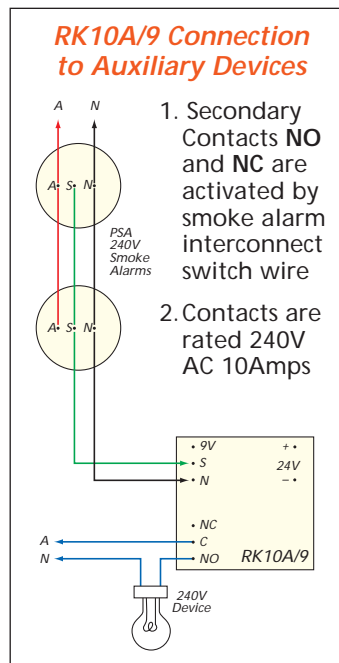

Another Quality Product from:
PSA Products
FIRE • SECURITY • INTERCOMS

17 Millicent St, Burwood, Vic 3125 Australia
Telephone: (03) 9888 9889 Facsimile: (03) 9888 9993
e-mail: enquiry@psaproducts.com.au

www.psaproducts.com.au



Quality System
Quality Endorsed Company
ISO 9001 Lic 8202
SAI Global