

# Programming Guide for PSA Panacom and Centrii Door Station with keypad

PAN921SCKP & CEN27DSKP

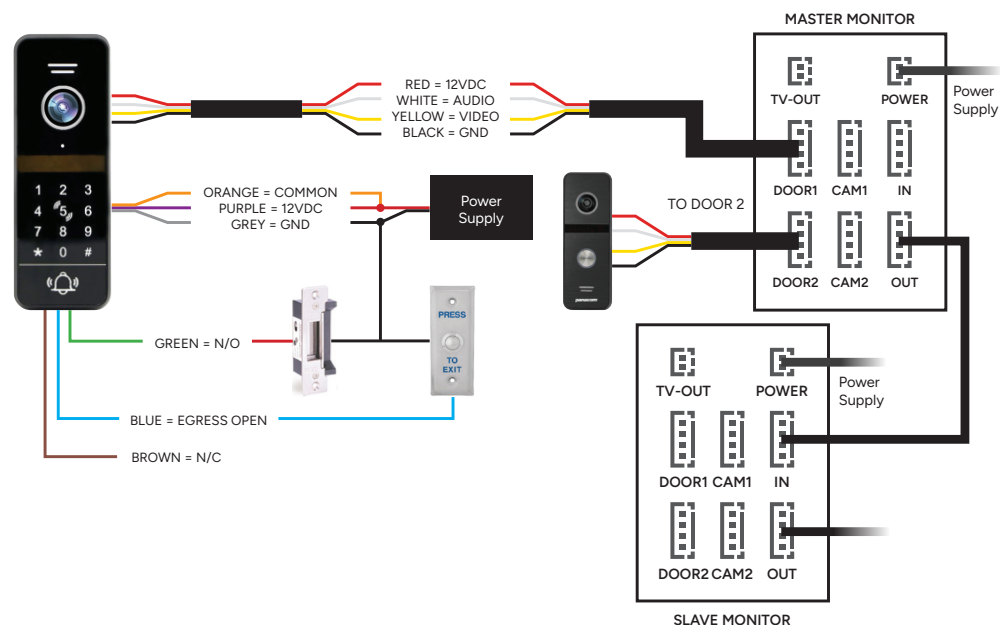

## WIRING DIAGRAM



## 1. SPECIFICATIONS

Input Voltage	12-15VDC
Current	Standby: ≤30mA, Working: ≤70mA
RFID Tag Frequency	13.56 MHz Mifare
Maximum RFID capacity	200 (000-199)
Maximum User PIN codes	200
Resolution	PAN921SCKP: 720P INT27DSKP: 1080P
Viewing angle	120°

\*NOTE: User PIN Codes can only be programmed together with a KEYFOB.  
If no KEYFOB is used, only the Public Access Code can be used.

## 2. CODE PROGRAMMING

### Programming code definitions:

- Programming code = P
- New code entry = N
- Access code = A
- User code = U

NOTE: codes cannot be sequential or all the same digit, eg. 111111 or 123456 will not work.

### a. Changing Programming Code (Default is 999999)

STEPS	INPUT	RESPONSE	NOTES
1	[*] + [PPPPPP] + [#]	Keypad will beep twice and flash slowly	P= existing Programming code to be changed. (default is 999999) Enters programming mode
2	[0]	Keypad will flash quickly	Code setting address
3	[77] + [#]	Keypad will continue flashing	Programming code setting address
4	[NNNNNN] + [#]	Keypad will beep once	N= New Programming code to replace existing. Must be 6-digits
5	[NNNNNN] + [#]	Keypad will beep twice and flash slowly	Confirm New Programming code and return to Programming mode.
6	[*]	Keypad will stop flashing	Exit programming mode

### b. Changing Public Access Code (Default is 123456)

STEPS	INPUT	RESPONSE	NOTES
1	[*] + [PPPPPP] + [#]	Keypad will beep twice and flash slowly	P= Programming Code. Enters programming mode
2	[0]	Keypad will flash quickly	Code setting address
3	[11] + [#]	Keypad will beep once and continue flashing	Public Access code setting address
4	[NNNNNN] + [#]	Keypad will beep once	N= New access code (4 to 6 Digits) to replace existing code
5	[NNNNNN] + [#]	Keypad will beep twice and flash slowly	Confirms new access code and return to Programming mode
6	[*]	Keypad will stop flashing	Exit programming mode

### c. Setting lock output time

STEPS	INPUT	RESPONSE	NOTES
1	[*] + [PPPPPP] + [#]	Keypad will flash slowly	P= Programming Code. Enters Programming mode
2	[4]	Keypad will flash fast	Code setting address
3	[NN] + [#]	Keypad will beep twice and flash slowly	NN = seconds between 00-99
4	[*]	Keypad will stop flashing	Exit programming mode

# Programming Guide for PSA Panacom and Centrii Door Station with keypad

PAN921SCKP & GEN27DSKP



## 3. KEY FOB PROGRAMMING

### a. Setting Programmer FOB's

STEPS	INPUT	RESPONSE	NOTES
1	[*] + [PPPPPP] + [#]	Keypad will beep twice and flash slowly	P= Programming Code. Enters Programming mode
2	[6] + [#]	Keypad will flash fast	FOB programming mode
3	Tap 'Plus' FOB*	Keypad will beep twice	Sets as Adding FOB
4	Tap 'Minus' FOB*	Keypad will beep twice and will flash slowly	Sets as Removal FOB and returns to Programming mode
5	[*]	Keypad will stop flashing	Ends Programming mode

\* The plus and minus printed on the Fobs are for convenience, any FOB can be set as programming FOBs.

### b. Adding User FOB's using Programming FOB's

STEPS	INPUT	Response	Notes
1	Tap "Plus" FOB three times quickly	Keypad will beep three times and flash slowly	Enters quick FOB programming mode
2	Present new user FOBs in sequence	Keypad will beep twice for every successful addition. Keypad will Beep 4 times if FOB had already been added to this keypad.	Repeat sequence until all FOBS have been added.
3	Present "Plus" FOB	Keypad will beep once and stop flashing	Ends Programming mode

### c. Removing User FOB's using Programming FOB's

STEPS	INPUT	Response	Notes
1	Tap "Minus" FOB three times quickly	Keypad will beep three times and flash slowly	Enters quick FOB programming mode
2	Present user FOBs to be removed in sequence	Keypad will beep twice	Repeat sequence until all FOBs have been added. Keypad will Beep 4 times if FOB has already been removed to this keypad.
3	Present "Minus" FOB	Keypad will beep once and stop flashing	Ends Programming mode

## 4. CHANGING USER ACCESS CODES

STEPS	INPUT	Response	Notes
1	[*] + Touch programmed FOB to keypad	Keypad will beep twice 4 beeps = FOB not programmed	Only programmed FOBs can have user access codes programmed
2	[UUUU] + [#]	Keypad will beep twice and flash slowly	U= Existing user code (default is 0000). Enters user code programming
3	[NNNN] + [#]	Keypad continues to flash slowly	N= new user access code
4	[NNNN] + [#]	Keypad will beep once and stop flashing	Confirm new user access code and exit programming mode.

## 5. HARD FACTORY RESET

1. Disconnect power
2. Short the blue & grey wires and reconnect power
3. Keypad will beep 3 times
4. Remove the short from blue & grey wires

## 6. SOFTWARE FACTORY RESET

STEPS	INPUT	Response	Notes
1	[*] + [PPPPPP] + [#]	Keypad will beep twice and flash slowly	P= Programming Code. Enters Programming mode
2	[0]	Keypad will flash quickly	Enters administration control
3	[99] + [#]	Keypad will flash slowly	Reset command and returns to Programming mode
4	[*]	Keypad will beep once and stop flashing	Exit programming mode

NOTE: Sections 5 & 6 procedures do not delete the FOBs or User Access Codes

## 7. REMOVE ALL USER FOBS AND USER CODES

STEPS	INPUT	Response	Notes
1	[*] + [PPPPPP] + [#]	Keypad will beep twice and flash slowly	P= Programming Code. Enters Programming mode
2	[2]	Keypad will flash quickly	Enters administration control
3	[88] + [#]	Keypad will beep seven times and flash slowly	All User ID information and assigned key FOBs have been deleted
4	[*]	Keypad will beep once and stop flashing	Ends Programming mode

NOTE: Does not remove Programming FOBs. Programming FOBs can only be replaced.



PSA Products Pty Ltd

17 Millicent St, Burwood, VIC 3125 Australia

T. 1300 772 776 | enquiry@psaproducts.com.au

psaproducts.com.au

Produced by PSA Products (psaproducts.com.au). Version 3 (July 2025)