

PENDANT MOUNT

HLDS-1271ZJ-PT10

Feature

- Aluminum alloy and plastic with surface spray treatment
- The cap facilitates the installation

Dimensions

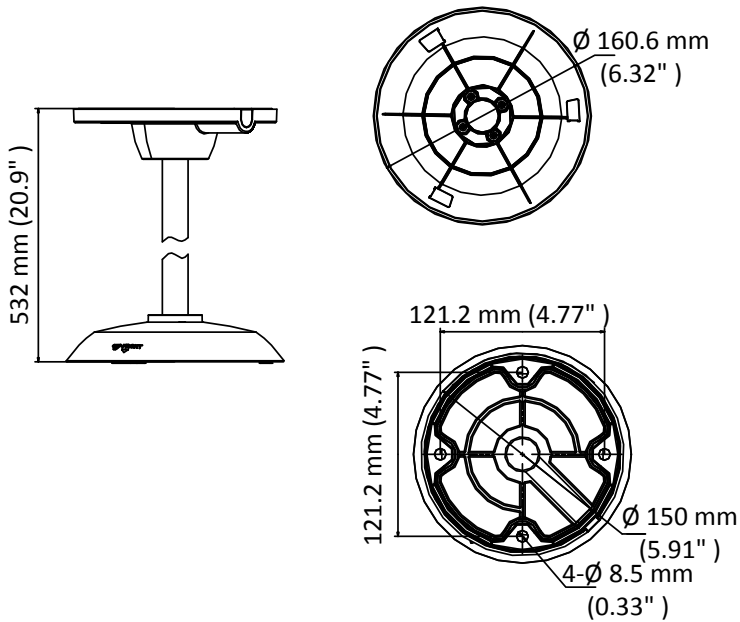

To Suit Model:

HLPTZ-P332ZI-DE3

Parameter

Model	DS-1271ZJ-PT10
Parameters	Pendant Mount
Appearance	Hikvision White
Material	Aluminum Alloy and Plastic
Dimension	$\varnothing 160.6$ mm \times 532 mm (6.32" \times 20.9")
Weight	1300 g (2.87 lb.)

Note

- The mount should be installed on the flat surface.
- The waterproof rubber is necessary for the outdoor application.
- The wall must be capable of supporting at least 3 times as much as the total weight of the camera, and the mount.
- The mount's maximum load capacity is 3 kg (6.61 lb.).