

CORNER MOUNT BRACKET

HLDS-1276ZJ-SUS

Feature

- Stainless steel with surface spray treatment
- One piece stainless steel formation ensures the reliable structure
- Expand camera's field of view

Dimension

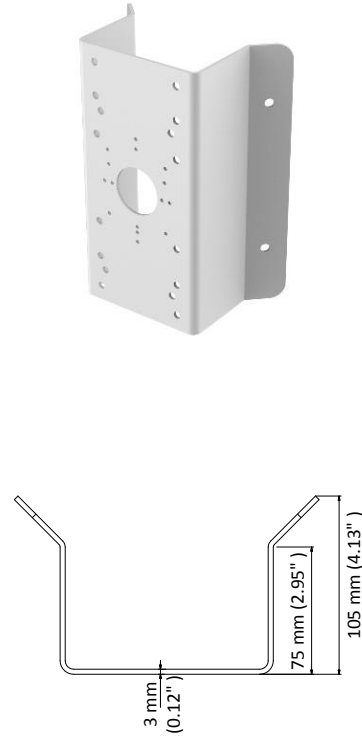
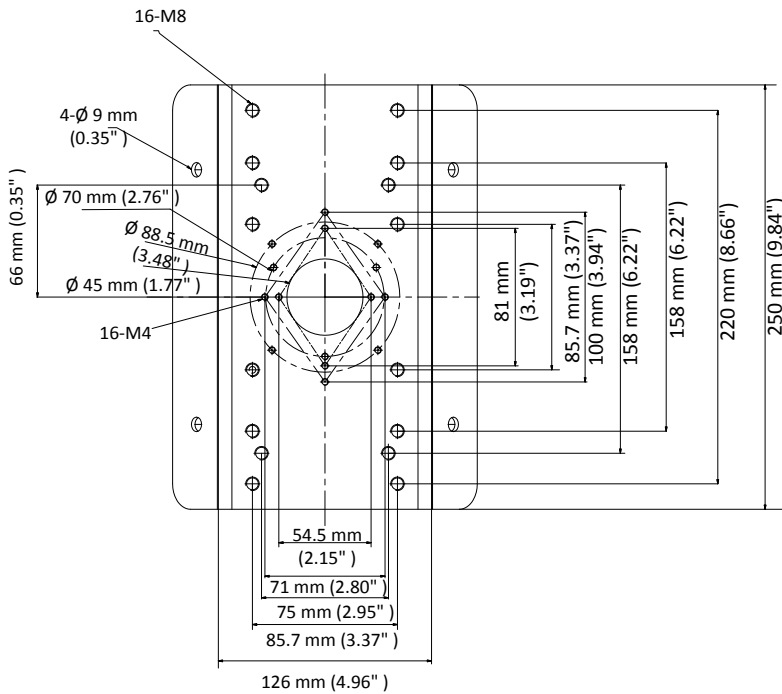

Model Suitable:

HLTHC-T120-M, HLIPC-T240H, HLIPC-T250H, HLIPC-T280H, HLIPC-D640H-Z

Parameter

Model	DS-1276ZJ-SUS
Parameters	Corner Mount
Appearance	Hikvision White
Material	Stainless Steel
Dimension	126 mm × 105 mm × 250 mm (4.96" × 4.13" × 9.84")
Weight	1990 g (4.39 lb.)

Note

- The mount should be installed on the flat surface.
- The waterproof rubber is necessary for the outdoor application.
- The wall must be capable of supporting at least 3 times as much as the total weight of the camera, and the mount.
- The mount's maximum load capacity is 10 kg (22 lb.).